

Item
Model
ProjectName



## K120

K120 two speed food processor has a vertical spindle and is designed for use in catering kitchens and the food preparation industry. This allows mixing and mincing easily and fast which preserves the texture and flavour of the products.

603295

## FEATURES

- Lower housing made of aluminium with bead blast finish.
- The transparent polycarbonate cover can be removed without tools and is dishwasher safe.
- The motor drives the angled cutter of speeds of 1500 and 3000 rpm.
- The speed of rotation allows all sorts of preparations to be carried out in a matter of seconds:
  - Mincing meats (tartare, sausage meat, pâtés, stuffing, mousses, etc.)

- Chopping condiments (parsley, garlic, onions, shallots, spices, etc.).
- Preparation of mayonnaise, mashes, flavoured butters, purées, compotes, etc.
- Liquidising frozen foodstuffs, fish soups with shellfish, etc.
- Preparation of all types of pastry.
- Pastrywork (almond paste, sugared almonds, half and half, etc.).

# Food Processors



**DITO**

**Electrolux**

- The stainless steel bowl is supplied complete with a leak resistant spout and has a transparent lid with a watertight seal and a large central rotating shaft that allows liquids to be mixed without overflowing.
- The spout allows products to be added in mid-cycle without stopping the machine.
- The blades are angled and the base of the bowl is conical to ensure consistent mixing every time.
- Operator safety is guaranteed by the presence of a magnetic microswitch which stops the machine whenever the lid or the bowl are not correctly positioned.
- A safety device stops the machine from restarting after a power cut until the operator presses the start button.
- The touch control panel allows the entire machine to be cleaned with a jet of water (IP66 water protection).

## Specifications

MODEL	K120F4 603295	K120F4SR 603296
External dimensions - mm		
width	416	416
depth	680	680
height	517	517
Mincing capacity - kg/cycle		
meats	5	5
Preparation mayonnaise/sauces - kg/cycle		
mayonnaise	6	6
Power - kW		
installed-electric	2.2	2.2
Net weight - kg.	58	58
Supply voltage	400...415 V, 3, 50	400...415 V, 3, 50



**DITO****Electrolux**

## Included accessories

CODE	DESCRIPTION	K120F4 603295	K120F4SR 603296
653270	11.5 LITRE S/S BOWL FOR CUTTER-MIXER	1	1
653299	SERRATED BLADE ROTOR -11.5L CUTTER-MIXER		1
653179	SMOOTH BLADE ROTOR FOR 11.5 CUTTER-MIXER	1	

## Optional accessories

CODE	DESCRIPTION	K120F4 603295	K120F4SR 603296
653270	11.5 LITRE S/S BOWL FOR CUTTER-MIXER	✓	✓
653277	EQUIPPED SCRAPER FOR 11.5L CUTTER-MIXER	✓	✓
653017	S/S MOBILE STAND	✓	✓
653299	SERRATED BLADE ROTOR -11.5L CUTTER-MIXER	✓	✓
653538	SERRATED ROTOR-MEAT-11.5L CUTTER-MIXER	✓	✓
653179	SMOOTH BLADE ROTOR FOR 11.5 CUTTER-MIXER	✓	✓



**DITO**

**Electrolux**

## Installation drawings

603295, 603296

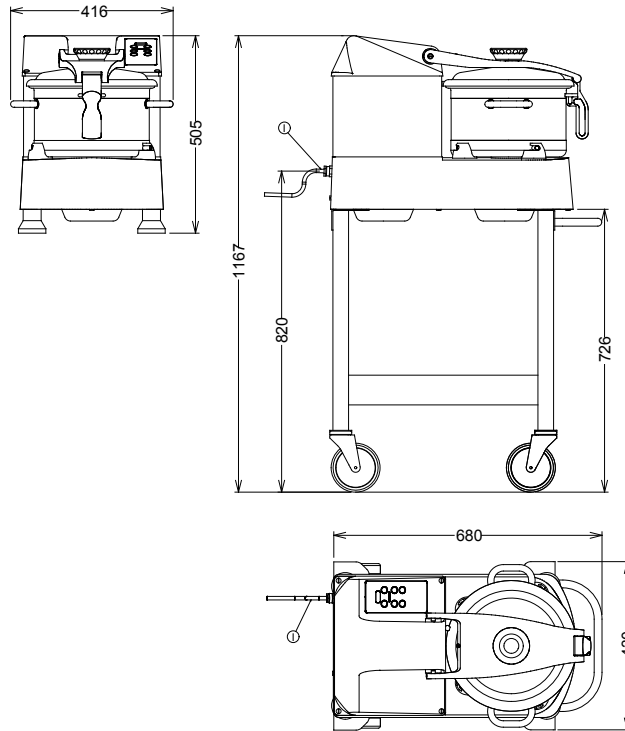

**MODEL**

I - Electrical connection

**K120F4  
603295**

400...415 V, 3, 50

**K120F4SR  
603296**

400...415 V, 3, 50

The manufacturer reserves the right to modify and make improvements to the products without giving prior warning. Dimensions, illustrations, technical data, weights, etc. are given as an indication only.



[www.dito-electrolux.com](http://www.dito-electrolux.com)

# Food Processors



ABE010